

# Bryan "Flexible Water Tube" HE-RV Series Water Boilers

3,500,000 to 8,000,000 BTUH  
Forced draft gas fired



Model  
HE-RV800-W-FDG

- With HE-RV Series Boilers, you get a guaranteed 85% combustion efficiency resulting from a uniquely designed integrated extended surface heat extractor.
- What's more, HE-RV Boilers offer high operating efficiency — all at normal operation temperatures — without providing for the expense or complications of special venting and/or condensing material.

## Quality Construction Features

- A. Heavy steel boiler frame, built and stamped in accordance with the ASME Boiler Code.
- B. Large volume water leg downcomers located inside the furnace chamber promote rapid internal circulation, temperature equalization and efficient heat transfer.
- C. Bryan 1½" bent water tubes are flexible, individually replaceable without welding or rolling. Never more than two tube configurations.
- D. Boiler tube and furnace area access panel: heavy 11 gauge steel casing with 4" high temperature ceramic fiber insulation, bolted and tightly sealed to boiler frame.
- E. Pressurized design firebox with internal water-cooled furnace for low heat release rate.
- F. Heavy 18 gauge steel boiler jacket with rust-resistant zinc coating and durable enamel finish, lined with 1½" fiberglass insulation to insure exceptionally cool outer surface.
- G. Minimum sized flue vent.
- H. Forced draft, flame retention head type burner. Efficient combustion and quiet operation.
- I. All controls, gauges, relief valve(s) are factory installed and wired and easily accessible for servicing.
- J. Control panel: all controls installed and connected to terminal strip.
- K. Water side interior accessible for cleanout and inspection, front and rear openings in upper and lower drums.
- L. Flame observation port in rear of boiler.
- M. Single side access; combustion chamber, tubes and burner head are completely accessible from one side simplifying maintenance and minimizing floor space.

## Bryan HE-RV Series Boiler Specifications

BOILER MODEL	INPUT MBH (KW)	NOMINAL OUTPUT		HTG. SURFACE SQ. FT. (M <sup>2</sup> )	APPROX. SHIP WT. LBS. (KG)
		MBH (KW)*	BHP*		
HE-RV350	3,500 (1,025.5)	2,975 (841.7)	89 (870.9)	663 (61.6)	7,515 (3,408.8)
HE-RV400	4,000 (1,172.0)	3,400 (996.2)	102 (995.4)	774 (71.9)	8,291 (3,760.8)
HE-RV450	4,500 (1,318.5)	3,825 (1,120.7)	114 (1,119.8)	869 (80.8)	9,006 (4,068.0)
HE-RV500	5,000 (1,465.0)	4,250 (1,245.2)	127 (1,244.2)	963 (89.5)	9,852 (4,468.9)
HE-RV550	5,500 (1,611.0)	4,675 (1,369.8)	140 (1,368.6)	1,035 (96.2)	10,592 (4,804.5)
HE-RV600	6,000 (1,758.0)	5,100 (1,494.3)	152 (1,493.1)	1,128 (104.8)	11,381 (5,162.4)
HE-RV700	7,000 (2,051.0)	5,950 (1,743.3)	178 (1,741.9)	1,335 (124.1)	12,990 (5,892.3)
HE-RV800	8,000 (2,344.0)	6,800 (1,992.4)	203 (1,990.7)	1,541 (143.2)	18,652 (6,646.1)

NOTES : (1) Output and horsepower based on an average natural gas combustion efficiency of 85%.

**Guaranteed  
85% efficiency**

**Plus 7 sq. ft.  
of heating surface  
per boiler horsepower**



# BRYAN® BOILERS

Originators of the "Flexible Water Tube" design

# Bryan HE-RV Series Gas Fired Flexible Tube Boilers

## Efficient Water Tube Design

The Bryan Flexible Water Tube provides for extremely fast internal circulation for maximum heat transfer and operating efficiency.

## No "Thermal Shock"

The flexibility of the bent water tube design eliminates all possible damage from "Thermal Shock" and from stresses caused by poor or unequal internal circulation. This is particularly important with forced hot water heating systems designed for higher temperatures and greater temperature drops.

## Natural Internal Circulation

The water tube design and the large water leg downcomers provide adequate internal circulation without concern over exterior pumping conditions. Low pressure drop through boiler.

## Compact — Minimum Floor Space

Requires less floor space due to the unique tube/boiler design which results in minimum foot print. Even greater space saving is achieved when incorporating a second boiler with reverse construction.

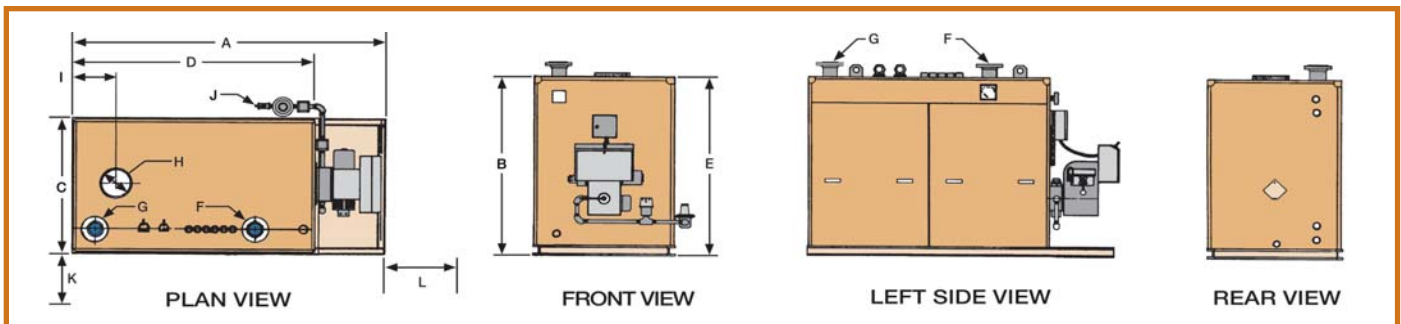

WATER BOILER DIMENSIONS — inches (cm)

Boiler Model Number	A Overall Length	B Floor to Flow Nozzle	C Width Outside Jacket	D Length of Jacket	E Height Over Jacket	F Supply Nozzle	G Return Nozzle	H Flue Size	I Flue Location	J Gas Train* Connection (Approx.)	K Min. Tube Removal Clearance	L Clearance for Servicing Burner
HE-RV350	130½ (331.5)	90 (228.6)	50 (127.0)	98 (248.9)	87½ (222.3)	4 (10.2)	4 (10.2)	16 (40.6)	14 <sup>3</sup> / <sub>8</sub> (36.5)	2½ (6.35)	32 (81.3)	48 (121.9)
HE-RV400	143½ (364.5)	90 (228.6)	50 (127.0)	111 (281.9)	87½ (222.3)	6 (15.2)	6 (15.2)	16 (40.6)	14 <sup>3</sup> / <sub>8</sub> (36.5)	2½ (6.35)	32 (81.3)	48 (121.9)
HE-RV450	153¾ (389.3)	90 (228.6)	50 (127.0)	120½ (306.0)	87½ (222.3)	6 (15.2)	6 (15.2)	16 (40.6)	14 <sup>3</sup> / <sub>8</sub> (36.5)	2 (6.35)	32 (81.3)	48 (121.9)
HE-RV500	163 (414.0)	90 (228.6)	50 (127.0)	130¼ (330.8)	87½ (222.3)	6 (15.2)	6 (15.2)	16 (40.6)	14 <sup>3</sup> / <sub>8</sub> (36.5)	2 (5.08)	32 (81.3)	48 (121.9)
HE-RV550	175¾ (446.4)	90 (228.6)	50 (127.0)	143½ (363.9)	87½ (222.3)	6 (15.2)	6 (15.2)	16 (40.6)	14 <sup>3</sup> / <sub>8</sub> (36.5)	2½ (5.08)	32 (81.3)	48 (121.9)
HE-RV600	185¼ (470.5)	90 (228.6)	50 (127.0)	152¾ (387.9)	87½ (222.3)	6 (15.2)	6 (15.2)	16 (40.6)	14 <sup>3</sup> / <sub>8</sub> (36.5)	2½ (6.35)	32 (81.3)	48 (121.9)
HE-RV700	214½ (544.8)	90 (228.6)	50 (127.0)	175¾ (445.1)	87½ (222.3)	6 (15.2)	6 (15.2)	20 (50.8)	16 <sup>3</sup> / <sub>8</sub> (41.6)	2½ (6.35)	32 (81.3)	48 (121.9)
HE-RV800	237¼ (602.6)	90 (228.6)	50 (127.0)	197¾ (502.3)	87½ (222.3)	6 (15.2)	6 (15.2)	20 (50.8)	16 <sup>3</sup> / <sub>8</sub> (41.6)	2½ (6.35)	32 (81.3)	48 (121.9)

NOTE: \*Gas train and control location dimensions will vary depending on job specifications and conditions. Dimensions and specifications are subject to change without notice. Consult factory for certified dimensions.

## Bryan HE-RV Series Boilers Standard and Optional Equipment

### STANDARD EQUIPMENT:

Combination thermometer and pressure gauge, ASME code-rated boiler relief valve, water temperature control (240°F max. std.), high limit control, probe LWCO. Electronic combustion safety control, automatic operating gas valve, safety gas valve, pilot solenoid valve, pilot ignition assembly, main manual gas shut-off valve, pilot cock, pilot and main gas pressure regulators, air safety switch,

control panel. Boiler/burner package shipped completely assembled with all controls installed and wired.

### OPTIONAL EQUIPMENT:

1. Manual reset high limit control
2. Manual reset low water cutoff
3. Auxiliary low water cutoff
4. Combination low water cutoff and feeder
5. Alarm buzzers (bell or horn)

6. UL, CSD-1, FM, GAP or other insurance approved control systems
7. Control panel mounted on boiler
8. Function indicators, as desired
9. Lead-lag systems for two or more boilers with or without outdoor reset control
10. Draft control system
11. Special construction, both knocked down and reverse
12. Low NO<sub>x</sub> package

### When ordering, please specify:

1. Boiler size
2. Supply and return temperatures required
3. Boiler relief valve setting
4. Type of fuel: natural, LP, or other gas
5. Gas BTU content, specific gravity and pressure available
6. Electric power voltage, phase and frequency
7. Optional extra equipment or construction
8. Special approvals required (UL, CSD-1, FM, or GAP)
9. Altitude



**Bryan Steam LLC — Leaders Since 1916**

783 N. Chili Ave., Peru, Indiana 46970 U.S.A.  
Phone: 765-473-6651 • Internet: www.bryanboilers.com  
Fax: 765-473-3074 • E-mail: bryanboilers@iquest.net