

Triple-Flex™

Ultra-High Efficiency Condensing Hot Water Boilers

Minimum 90% Thermal Efficiency
at 160°F Return with 20° Rise



*Patent
Pending*

 ENVIRONMENTAL
**CLAIMS
VALIDATION** ✓ MINIMUM 90% THERMAL EFFICIENCY
AT 160 F. RETURN, 20 F. RISE,
MAX. INPUT, TF150-300

Originators of the
"Flexible Water
Tube" design



 **BRYAN**®  **TRIPLE-FLEX**™



Low maintenance costs, high operating efficiency deliver substantial return on investment

All Bryan TF Series boilers offer these operating and performance features

Guaranteed efficiency

The breakthrough in ultra-high efficiency condensing water tube boiler design that produced the TF Series provides operating thermal efficiency so reliable, we guarantee it to be 90% at 160°F return with 20° rise.

The Bryan Flexible Tube

Flexible tubes are easily removable and replaceable, without welding or rolling, eliminating long, expensive downtime should repairs ever be required.

Water cooled furnace

The configuration of the water tubes provide a water cooled combustion chamber. Optimal spacing of the tubes create high velocity flue gas travel for maximum heat transfer.

Compact design, minimum floor space

Our compact water tube design delivers over nine square feet of heating surface area per HP. Needing only 27" for tube removal, and on only one side of the boiler, the TF Series boiler occupies very little space in the boiler room. Bryan's exclusive reverse construction feature brings maximum design flexibility to the engineer.

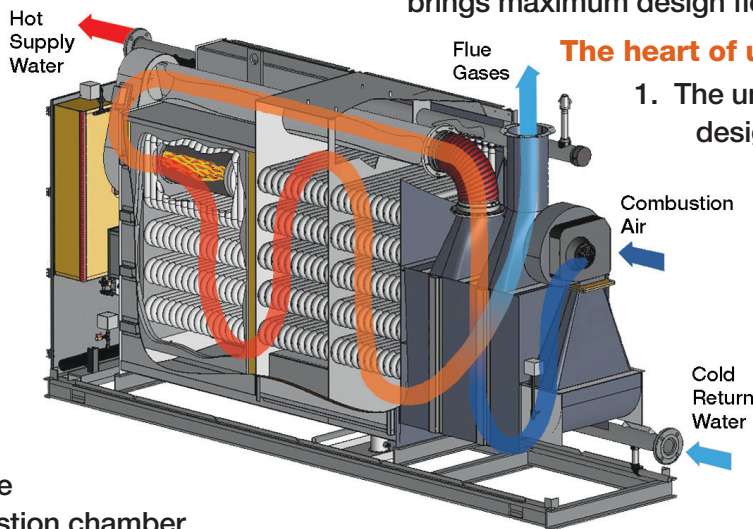

The heart of ultra-high efficiency

1. The unique three pass design in the combustion and convection sections of the boiler allow for maximum fireside heat transfer.
2. Gases continue to the combustion air preheater to recover free heat that would otherwise be wasted out the stack.
3. Resulting stack temperatures are less than half of other boilers.

Bryan Triple-Flex™ Series Boilers – Standard and Optional Equipment

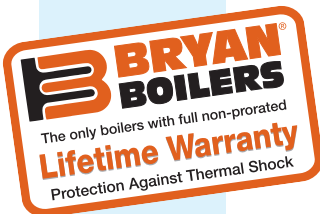

STANDARD EQUIPMENT FURNISHED Water Boiler

Thermometer and pressure gauge, safety relief valve, operator control. High limit control and probe type low water cutoff both with manual reset. Sub 30 ppm Low NOx. ASME Section IV boiler, 210°F./160# design with UL/C-UL Listing. CSD-1, FM & GE-GAP specifications.

Boiler Control Center

The control center will be provided with "SOLA" control,

remote reading temperature and pressure gauges, indicating lights – power, call for heat, fuel on and failure, a on-off switch and control reset. All controls including control circuit transformer will be installed and wired.

Gas Equipment

Burner firing shut-off valve, automatic operating gas valve, safety gas valve. High and low gas pressure switches, air and water flow switches, pilot solenoid valve, electric ignition, main manual gas shut-off

valve, gas pressure regulating actuator, pilot shut-off valve, pilot gas pressure regulator. Based on natural gas 1,000 BTU/CF supplied at 14" W.C. minimum – 2 PSIG maximum.

OPTIONAL EQUIPMENT

1. Auxiliary probe type low water cutoff
2. Auxiliary float type water cutoff (field mounted)
3. Alarm buzzer
4. IRI like specifications
5. Condensate neutralizer kit

1,500,000 to 3,000,000 BTUH Natural Gas Fired Triple-Flex™ Boilers

Quality Construction Features

Over nine square feet of heating surface per BHP.

Heavy gauge stainless steel combustion section is lined with high temperature ceramic fiber and insulation for optimal transfer of burner energy.

Easy single side access to tubes and burner.

Bryan's forced draft hybrid metal fiber type burner. Efficient combustion of gas with quiet operation.

Air to air heat exchanger housing constructed of heavy gauge stainless steel for exceptional durability. Variable speed blower provides pre-heated combustion air to the burner while saving energy over other designs.

Jacket panels are attractive and rust-resistant with durable powder coat finish, air insulated to insure exceptionally cool outer jacket surface. Easy access for service and inspection.

Convection section of boiler is heavy gauge stainless steel with easy access for inspection.

Bryan stainless steel bent water tubes are flexible, individually replaceable without welding or rolling. Never more than two tube configurations.

Electrical box: all controls installed and connected to terminal strip with access points for interface to EMS/BMS.

Honeywell SOLA

Exceptional system management provided with the Honeywell "SOLA" Hydronic Control. Touch screen display technology allows for complete monitoring and control of burner and boiler control points. The "SOLA" control is equipped with ModBus communications protocol for interface with EMS/BMS and is configurable to accept 4-20 Ma signal for temperature setpoint reset or firing rate. Outputs include flue gas and supply water temperature along with system pump control. Internal lead/lag function will stage up to 8 boilers for precise temperature control of the heating loop.

Efficiencies up to 99% will be delivered with lower temperature design systems.

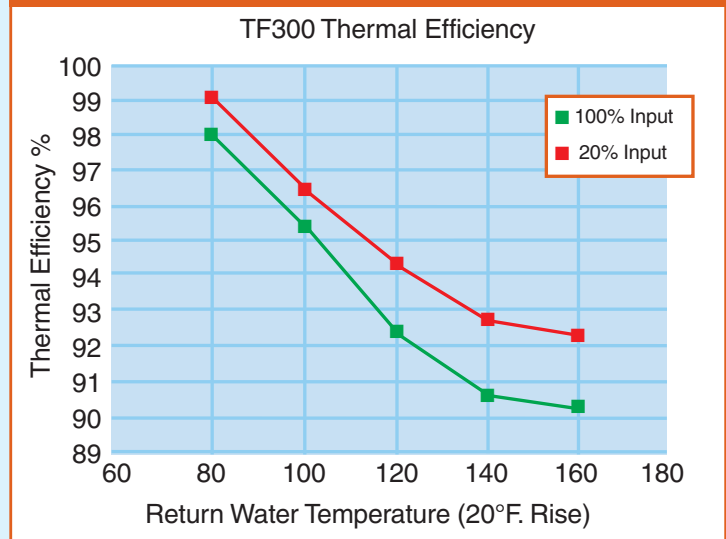

Bryan Triple-Flex™ Series Gas Fired Flexible Tube Boilers

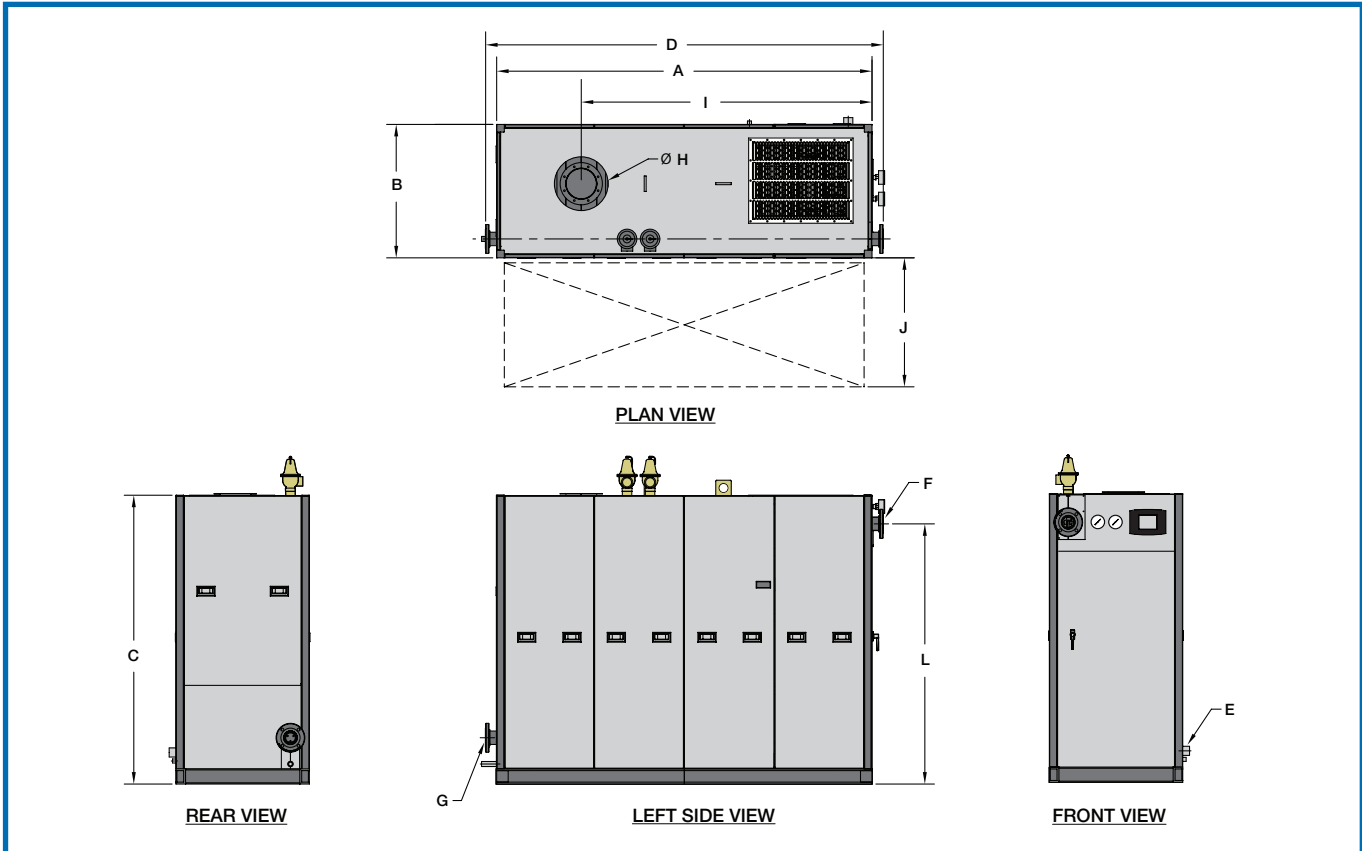

BOILER DIMENSIONS in inches (cm)											
BOILER MODEL NUMBER	A Length Of Jacket	B Width Outside Jacket	C Height Over Jacket	D Overall Length	E* Gas Train Connection	F Supply Nozzle	G Return Nozzle	H Flue Size	I Flue Location	J Min. Tube Removal Clearance	L Floor to Flow Nozzle
TF 150	122 7/8 (312.1)	34 3/4 (88.3)	75 1/4 (191.1)	128 3/4 (327.02)	2 NPT (5.1)	3 FLG (7.6)	3 FLG (7.6)	8 (20.3)	100 13/16 (256.06)	27 (68.6)	67 3/4 (172.1)
TF 200	122 7/8 (312.1)	34 3/4 (88.3)	75 1/4 (191.1)	128 3/4 (327.02)	2 NPT (5.1)	3 FLG (7.6)	3 FLG (7.6)	8 (20.3)	100 13/16 (256.06)	27 (68.6)	67 3/4 (172.1)
TF 250	144 1/4 (366.4)	34 3/4 (88.3)	75 1/4 (191.1)	150 1/8 (381.3)	2 NPT (5.1)	3 FLG (7.6)	3 FLG (7.6)	8 (20.3)	122 1/4 (310.5)	27 (68.6)	67 3/4 (172.1)
TF 300	144 1/4 (366.4)	34 3/4 (88.3)	75 1/4 (191.1)	150 1/8 (381.3)	2 NPT (5.1)	3 FLG (7.6)	3 FLG (7.6)	8 (20.3)	122 1/4 (310.5)	27 (68.6)	67 3/4 (172.1)

NOTE: *Gas train connection may vary depending on job specifications and conditions.
Dimensions and specifications are subject to change without notice. Consult factory for certified dimensions.

Bryan TF Series Boiler Specifications

BOILER MODEL	INPUT MBH (KW)	OUTPUT@ 90% MIN. EFFICIENCY with 160° F. Return*		OUTPUT@ 98% EFFICIENCY with 80° F. Return*		HEATING SURFACE SQ. FT. (M²)	APPROX. SHIP LBS. (KG)
		MBH (KW)	HP (KW)	MBH (KW)	HP (KW)		
TF 150	1,500 (439)	1,350 (395)	40 (395)	1470 (430)	44 (430)	678 (63)	3,545 (1,608)
TF 200	2,000 (586)	1,800 (527)	54 (527)	1960 (574)	59 (578)	678 (63)	3,545 (1,608)
TF 250	2,500 (732)	2,250 (659)	67 (659)	2450 (717)	73 (716)	782 (72)	4,080 (1,850)
TF 300	3,000 (879)	2,700 (791)	81 (790)	2940 (861)	98 (959)	782 (72)	4,080 (1,850)

NOTE: *Output and horsepower based on 20 degree F. Delta T and maximum firing rate.



Bryan Steam LLC — Leaders Since 1916
783 N. Chili Ave., Peru, Indiana 46970 U.S.A.
Phone: 765-473-6651 • Internet: www.bryanboilers.com
Fax: 765-473-3074 • E-mail: inquiry@bryansteam.com